

CATALOG

V.24

DTECH[®]
solutions

LEAN MANUFACTURING

steel series

YOUR IMAGINATION IS THE LIMIT

www.dtechsolutions.com.br

		<p>PIPES</p> <p>04</p> <p>T Series</p>
		<p>METAL JOINTS</p> <p>07</p> <p>HJ Series</p>
		<p>METAL JOINTS</p> <p>13</p> <p>H Series</p>
		<p>ROLLER TRACKS</p> <p>17</p> <p>R Series</p>
		<p>PLASTICS</p> <p>28</p> <p>P Series</p>
		<p>METAL ACCESSORIES</p> <p>32</p> <p>L Series</p>
		<p>LEVELING FEET</p> <p>37</p> <p>L Series</p>
		<p>FASTENERS</p> <p>41</p> <p>N Series</p>
		<p>CASTERS</p> <p>43</p> <p>C Series</p>
		<p>SQUARE PIPE</p> <p>46</p> <p>S Series</p>



T Series

PIPES

PIPES

Coated Pipe



1. Production Craft

This craft includes single-step and automatic integrated process.

Because of the high cost of the first craft, RELL suggests the second one. Moreover, we have successfully researched the automatic integrating pipe craft.

2. Performance and Parameters

Pipe is composed of five parts.

It can be provided according to customers different requirements on performance.

SUS Pipe



1. High Strength & Durability

Surface resistant to light abrasion or contact with metal tools.

2. High Oil & Chemical Resistance

High resistance to oil, solvents, bleaches, etc.

3. Non-flammable

Inherently non-flammable.

4. Conductive

Inherently conductive.

5. Environmental

SUS pipe is fully recyclable.

Aluminum Alloy Pipe



1. Environmental

Aluminum pipe achieves a superb recyclability.

2. Weight

Weight reduced by 40% comparing with steel coated pipe.

3. Aesthetic

Alumite treatment allows for "maintenance-free", excellent appearance that lasts for long.

PE Coated Pipe 4000	28 x 0.7	28 x 0.9	28 x 1.0	28 x 1.1	28 x 1.4	28 x 2.0
Green(N)	T-PE07N	T-PE09N	T-PE10N	T-PE11N	T-PE14N	T-PE20N
Blue(U)	T-PE07U	T-PE09U	T-PE10U	T-PE11U	T-PE14U	T-PE20U
Red(R)	T-PE07R	T-PE09R	T-PE10R	T-PE11R	T-PE14R	T-PE20R
Orange(E)	T-PE07E	T-PE09E	T-PE10E	T-PE11E	T-PE14E	T-PE20E
Yellow(Y)	T-PE07Y	T-PE09Y	T-PE10Y	T-PE11Y	T-PE14Y	T-PE20Y
LightYellow(LY)	T-PE07LY	T-PE09LY	T-PE10LY	T-PE11LY	T-PE14LY	T-PE20LY
Ivory(V)	T-PE07V	T-PE09V	T-PE10V	T-PE11V	T-PE14V	T-PE20V
Grey(G)	T-PE07G	T-PE09G	T-PE10G	T-PE11G	T-PE14G	T-PE20G
Dark Grey(DG)	T-PE07DG	T-PE09DG	T-PE10DG	T-PE11DG	T-PE14DG	T-PE20DG
Black(B)	T-PE07B	T-PE09B	T-PE10B	T-PE11B	T-PE14B	T-PE20B
Snow White(SW)	T-PE07SW	T-PE09SW	T-PE10SW	T-PE11SW	T-PE14SW	T-PE20SW
Milky White(MW)	T-PE07MW	T-PE09MW	T-PE10MW	T-PE11MW	T-PE14MW	T-PE20MW
ESD Pipe			28 x 1.0			
Black(B)			T-ESD10B			
SUS 201 Pipe	28 x 0.7	28 x 0.9		28 x 1.1		
	T-SUS07	T-SUS09		T-SUS11		
STS 409 Pipe	28 x 0.7		28 x 1.0		28 x 1.2	
	T-ST07		T-ST010		T-ST012	
	T-ST072440					
Aluminum Alloy Pipe					28 x 1.2	
					T-AL120X	

HJ Series METAL JOINTS

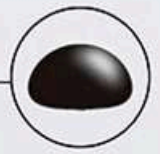

METAL JOINTS

SURFACE : ●BK ○WZ ○NP ○CP ●PC

H Series

HJ-1





H-1 : 2 pcs N-1/N-2 : 1 set



HJ-1A





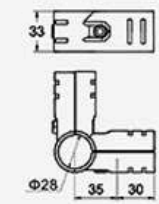

H-1A : 2 pcs N-1/N-2 : 1 set

HJ-2

H-2 : 1 pc
H-3 : 1 pc N-1/N-2 : 2 sets

HJ-3

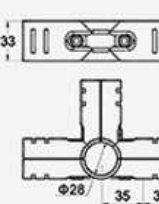
H-2 : 2 pcs
H-4 : 1 pc N-1/N-2 : 3 sets



HJ-4





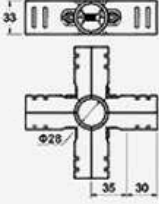

H-4 : 2 pcs N-1/N-2 : 2 sets

HJ-5

H-2 : 4 pcs N-1/N-2 : 4 sets

HJ-6

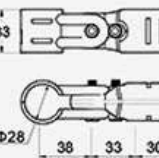
H-5 : 2 pcs
H-6 : 2 pcs N-1/N-2 : 2 sets



HJ-6A





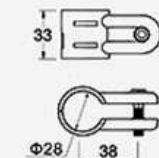

H-6 : 2 pcs
H-6A : 2 pcs N-1/N-2 : 3 sets

HJ-6B

H-5 : 2 pcs N-1/N-2 : 1 set

HJ-6C

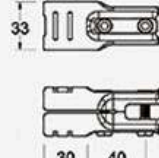

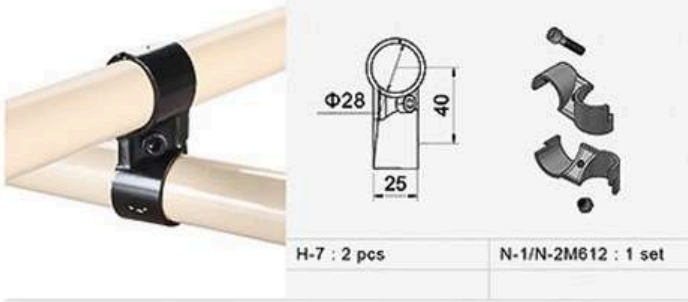

H-6A : 2 pcs N-1/N-2 : 2 sets

HJ-7

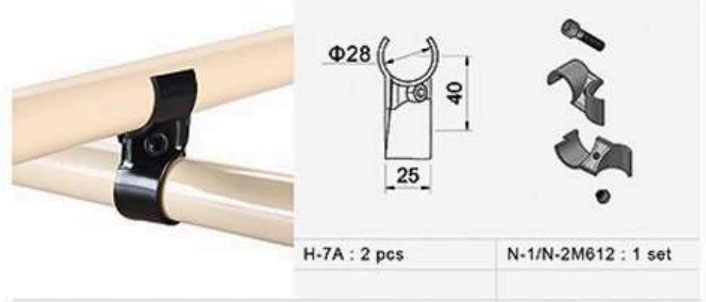

HJ-7A



HJ-8



HJ-9

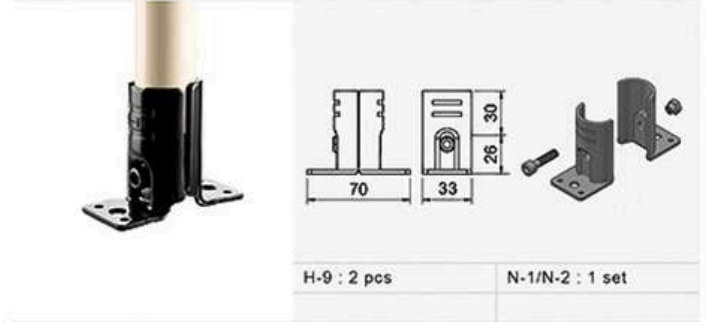

HJ-10

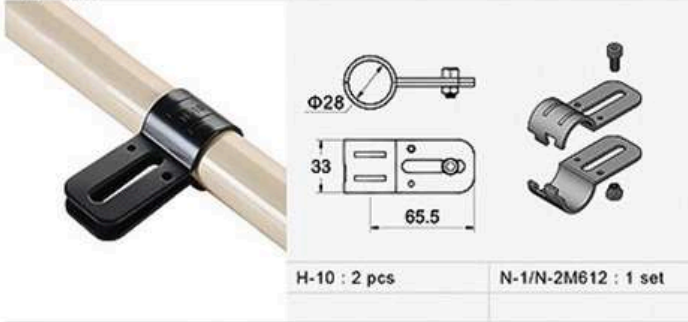

HJ-11

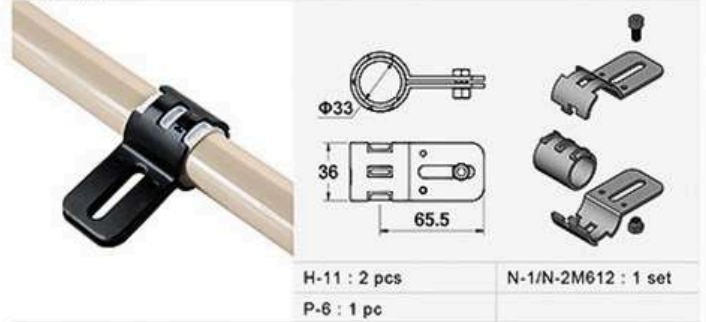

HJ-12

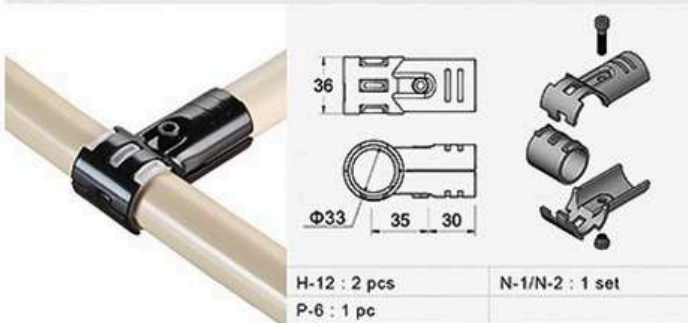

HJ-13

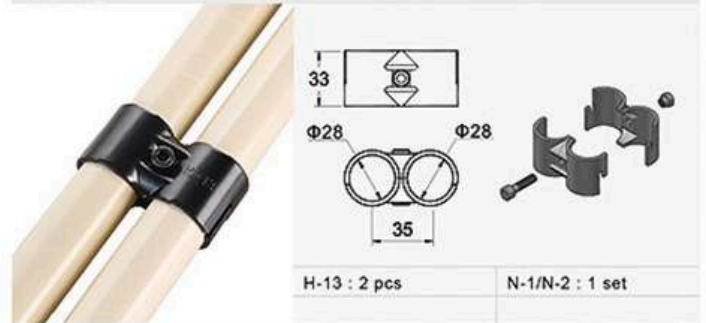

HJ-13A



HJ-13B



METAL JOINTS

SURFACE : ●BK ○WZ ○NP ○CP ●PC

HJ-14

H-14 : 2 pcs	N-1/N-2 : 4 sets
H-6 : 4 pcs	

HJ-14A

H-14 : 2 pcs	N-1/N-2 : 2 sets
--------------	------------------

HJ-15

H-15 : 1 pc	N-1/N-2M612 : 1 set
H-16 : 1 pc	

HJ-15A

H-15 : 1 pc	N-1/N-2M612 : 1 set
H-16A : 1 pc	

HJ-17

H-17 : 1 pc	N-1/N-2 : 1 set
H-18 : 1 pc	

HJ-19

H-19 : 2 pcs	N-1/N-2 : 1 set
P-6 : 2 pcs	

HJ-20

H-20 : 2 pcs	N-1/N-2 : 1 set
--------------	-----------------

HJ-20A

H-20 : 1 pc	N-1/N-2 : 1 set
H-1 : 1 pc	

HJ-21

H-21 : 2 pcs	N-1/N-2 : 1 set
--------------	-----------------

HJ-23

H-23 : 2 pcs	N-1/N-2 : 1 set
P-6 : 1 pc	

HJ-24

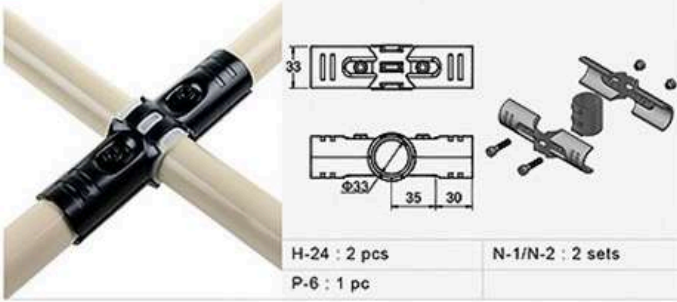

HJ-30



HJ-45

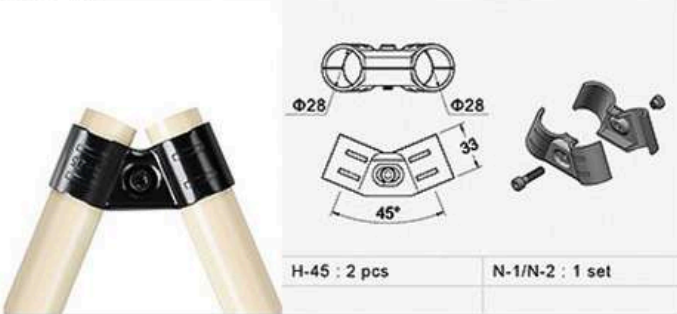

HJ-60



HJ-90

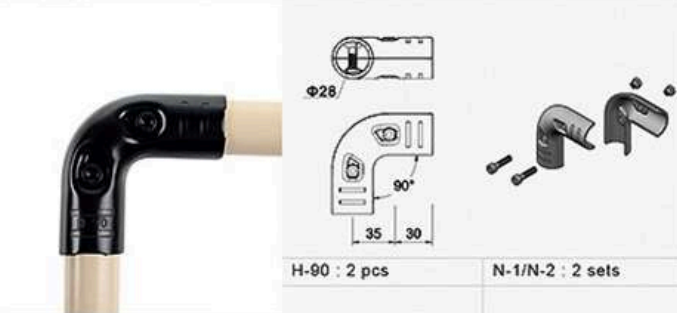

HJ-110

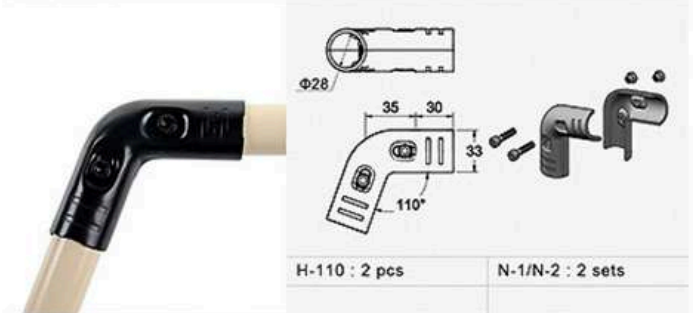

HJ-160

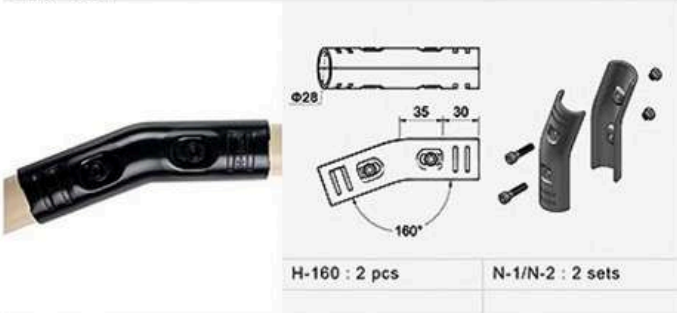

HJ-180

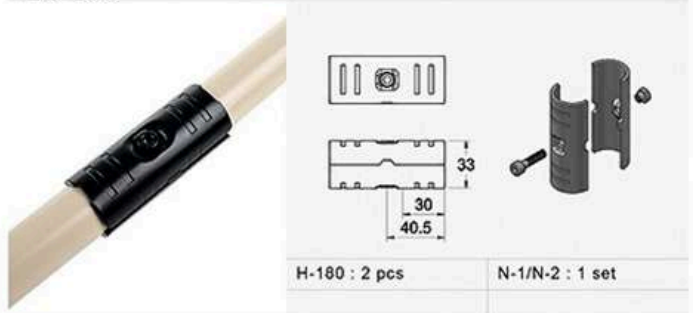

METAL JOINTS (Φ33)

SURFACE : ●BK ○WZ ○NP ○CP ●PC

HJ-103





H-103 : 2 pcs N-1/N-2 : 1 set

HJ-403

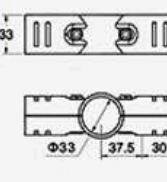
H-403 : 2 pcs N-1/N-2 : 2 sets



HJ-13C





H-13C : 2 pcs N-1/N-2 : 1 set

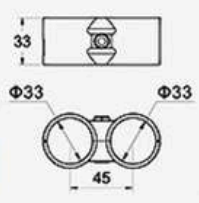

HJ-13D

H-13D : 2 pcs N-1/N-2 : 1 set

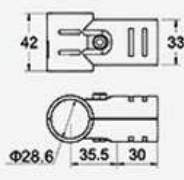

METAL JOINTS (Φ28.6)

HJ-101

H-101 : 2 pcs N-1/N-2 : 1 set

HJ-102

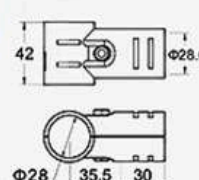
H-102 : 2 pcs N-1/N-2 : 1 set



HJ-201





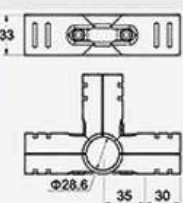

H-301 : 1 pc
H-2 : 1 pc N-1/N-2 : 2 sets

HJ-301

H-401 : 1 pc
H-2 : 2 pcs N-1/N-2 : 3 sets

HJ-401

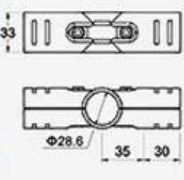
H-401 : 2 pcs N-1/N-2 : 2 sets

H Series

METAL JOINTS

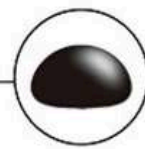

METAL JOINTS

SURFACE : ●BK ○WZ ○NP ○CP ●PC

H
Series

H-1



Kg/PC	0.067
PC/CTN	300

H-1A



Kg/PC	0.058
PC/CTN	360

H-2



Kg/PC	0.094
PC/CTN	200

H-3 (Ungrip Type)



Kg/PC	0.120
PC/CTN	80

H-3K (Grip Type)



Kg/PC	0.120
PC/CTN	80

H-4



Kg/PC	0.106
PC/CTN	200

H-5



Kg/PC	0.045
PC/CTN	300

H-6



Kg/PC	0.059
PC/CTN	300

H-6A



Kg/PC	0.066
PC/CTN	240

H-7



Kg/PC	0.048
PC/CTN	200

H-7A



Kg/PC	0.040
PC/CTN	300

H-8



Kg/PC	0.067
PC/CTN	240

H-9



Kg/PC	0.062
PC/CTN	330

H-10



Kg/PC	0.054
PC/CTN	300

H-11



Kg/PC	0.060
PC/CTN	280

H-12



Kg/PC	0.063
PC/CTN	240

H-13



Kg/PC	0.053
PC/CTN	300

H-13A



Kg/PC	0.052
PC/CTN	330

H-13B



Kg/PC	0.044
PC/CTN	540

H-14



Kg/PC	0.056
PC/CTN	320

H-15



Kg/PC	0.038
PC/CTN	400

H-16



Kg/PC	0.046
PC/CTN	400

H-16A



Kg/PC	0.046
PC/CTN	400

H-17



Kg/PC	0.069
PC/CTN	220

H-18



Kg/PC	0.069
PC/CTN	220

H-19



Kg/PC	0.062
PC/CTN	150

H-20



Kg/PC	0.070
PC/CTN	200

H-21



Kg/PC	0.133
PC/CTN	150

H-23



Kg/PC	0.064
PC/CTN	180

H-24



Kg/PC	0.102
PC/CTN	200

H-30



Kg/PC	0.062
PC/CTN	330

H-45



Kg/PC	0.066
PC/CTN	230

H-60



Kg/PC	0.083
PC/CTN	150

H-90



Kg/PC	0.102
PC/CTN	150

H-110



Kg/PC	0.113
PC/CTN	150

H-160



Kg/PC	0.114
PC/CTN	160

H-180



Kg/PC	0.071
PC/CTN	300

METAL JOINTS (Φ33)

SURFACE : ●BK ○WZ ○NP ○CP ●PC

H-103



Kg/PC	0.073
PC/CTN	240

H-403



Kg/PC	0.106
PC/CTN	200

H-13C



Kg/PC	0.069
PC/CTN	180

H-13D



Kg/PC	0.068
PC/CTN	180

METAL JOINTS (Φ28.6)

H-101



Kg/PC	0.078
PC/CTN	200

H-102



Kg/PC	0.078
PC/CTN	200

H-301



Kg/PC	0.120
PC/CTN	80

H-401



Kg/PC	0.108
PC/CTN	200

METAL JOINTS (T 2.3)

H-1



Kg/PC	0.061
PC/CTN	300

H-2



Kg/PC	0.086
PC/CTN	200

H-3 (Ungrip Type)



Kg/PC	0.111
PC/CTN	80

H-4



Kg/PC	0.098
PC/CTN	200

H-5



Kg/PC	0.042
PC/CTN	300

H-6



Kg/PC	0.055
PC/CTN	300

H-13A



Kg/PC	0.050
PC/CTN	330

H-15



Kg/PC	0.032
PC/CTN	400

H-16



Kg/PC	0.042
PC/CTN	400

H-17



Kg/PC	0.065
PC/CTN	220

H-18



Kg/PC	0.065
PC/CTN	220

H-90



Kg/PC	0.095
PC/CTN	150



R Series ROLLER TRACKS

R-40 36

— Shaft Distance

— Roller Track Width

ROLLER TRACKS

R-3533

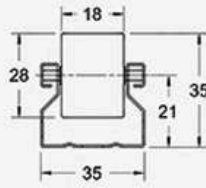

Kg/m	0.830
m/PC	4
m/BDL.	40

R-4036

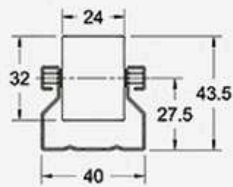
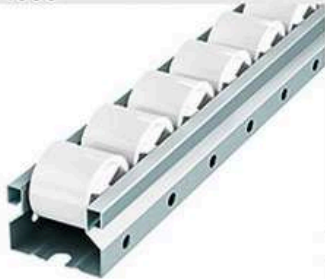

Kg/m	1.100
m/PC	3.99
m/BDL.	39.9

R-S4036

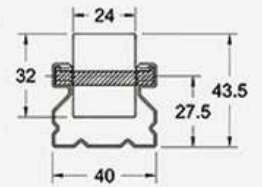

Kg/m	1.100
m/PC	4
m/BDL.	40

R-4036A

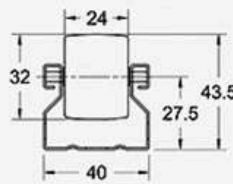
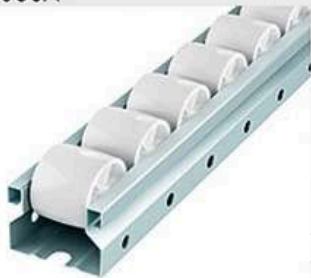

Kg/m	1.100
m/PC	3.99
m/BDL.	39.9

R-S4036A

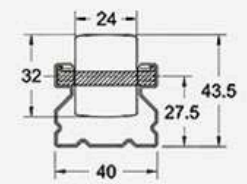

Kg/m	1.100
m/PC	4
m/BDL.	40

R-4045A

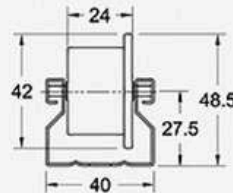
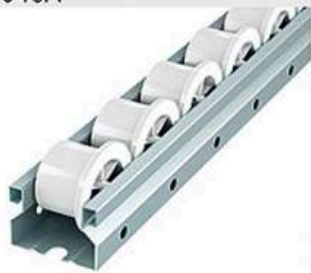

Kg/m	1.100
m/PC	4
m/BDL.	40

R-6016

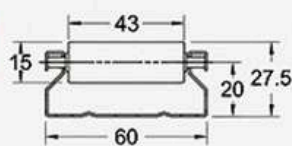

Kg/m	1.450
m/PC	4
m/BDL.	24

R-8040

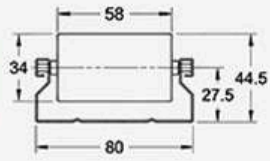
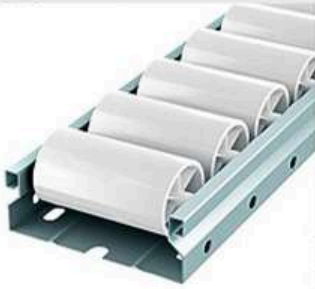

Kg/m	1.620
m/PC	4
m/BDL.	16

R-S8040

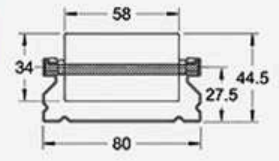

Kg/m	1.620
m/PC	4
m/BDL.	16

R-8519

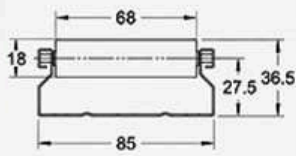

Kg/m	2.000
m/PC	4
m/BDL.	16

R-S8520

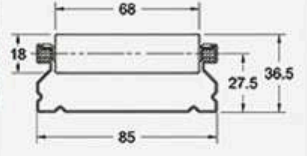

Kg/m	2.000
m/PC	4
m/BDL.	16

R-8550

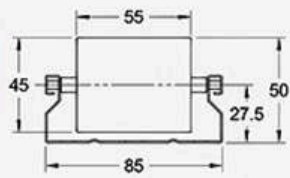
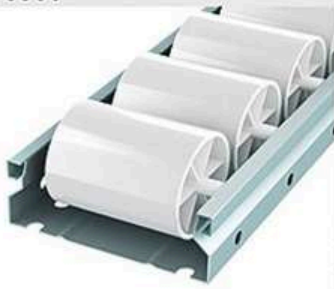

Kg/m	1.650
m/PC	4
m/BDL.	16

ROLLER TRACKS (R-28H)

SURFACE : ◯wz

R-28H1

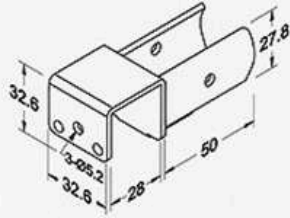

Kg/PC	0.128
PC/CTN	95

R-28H2

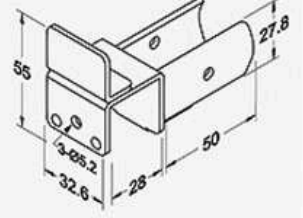
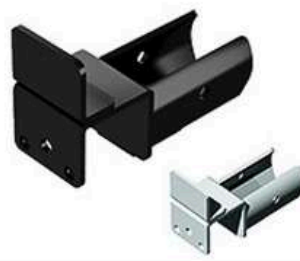

Kg/PC	0.150
PC/CTN	85

R-28H3

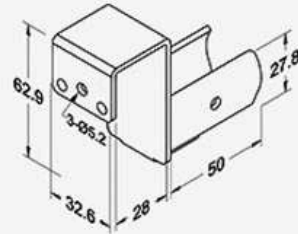

Kg/PC	0.153
PC/CTN	80

R-28H4B

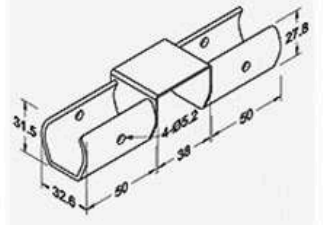

Kg/PC	0.171
PC/CTN	50

R-28H5

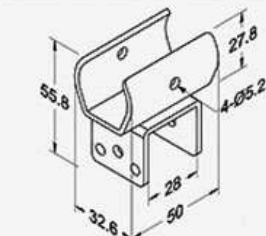

Kg/PC	0.112
PC/CTN	110

R-28H5B

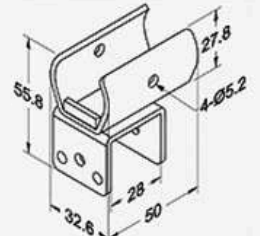

Kg/PC	0.117
PC/CTN	110

ROLLER TRACKS (R-35H)

R-35H1

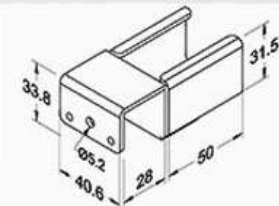

Kg/PC	0.167
PC/CTN	70

R-35H2

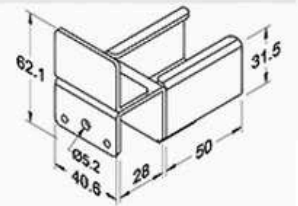

Kg/PC	0.211
PC/CTN	45

R-35H3A

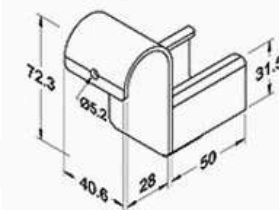

Kg/PC	0.191
PC/CTN	55

R-35H5

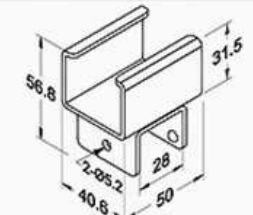

Kg/PC	0.137
PC/CTN	90

ROLLER TRACKS (R-40H)

R-40BH1

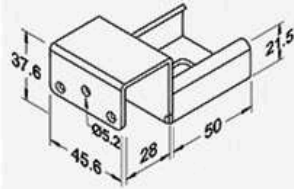
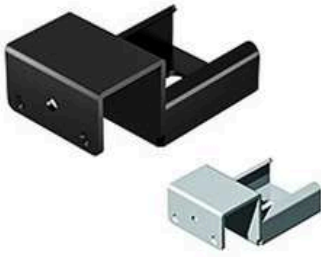

Kg/PC	0.141
PC/CTN	65

R-40BH2

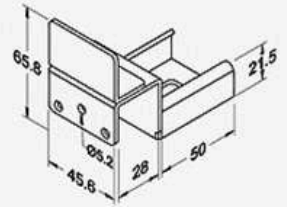
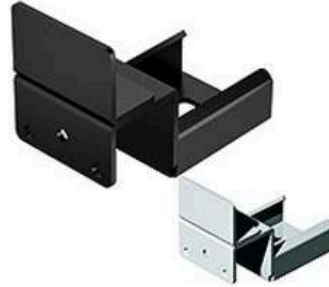

Kg/PC	0.193
PC/CTN	45

R-40BH3

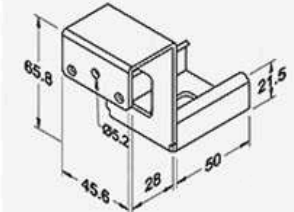

Kg/PC	0.167
PC/CTN	60

R-40BH4

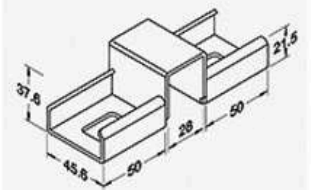
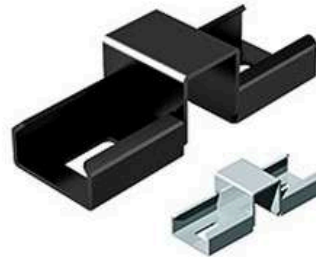

Kg/PC	0.270
PC/CTN	35

R-40BH5

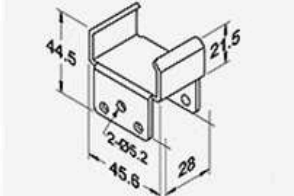

Kg/PC	0.120
PC/CTN	100

R-40BH6

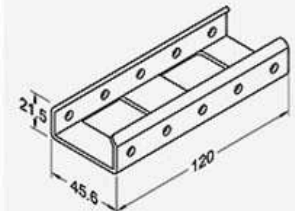

Kg/PC	0.180
PC/CTN	85

R-40BH6A

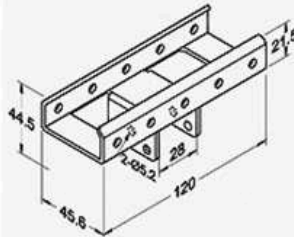

Kg/PC	0.230
PC/CTN	40

R-40BH31

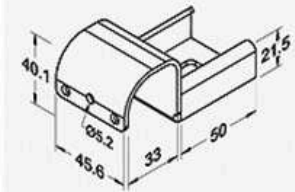

Kg/PC	0.180
PC/CTN	85

R-40BH33

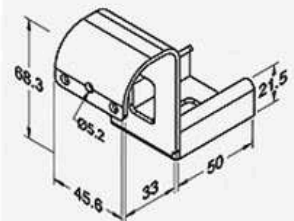

Kg/PC	0.230
PC/CTN	40

ROLLER TRACKS (R-40H)

SURFACE : ◉ wZ

R-40H1

Kg/PC	0.182
PC/CTN	45

R-40H2

Kg/PC	0.234
PC/CTN	45

R-40H3

Kg/PC	0.208
PC/CTN	40

R-40H6

Kg/PC	0.272
PC/CTN	50

R-40H6A

Kg/PC	0.320
PC/CTN	20

ROLLER TRACKS (RP-40)

RP-40A

Kg/m	0.980
m/PC	4
m/BDL.	40

RP-40B

Kg/m	0.660
m/PC	4
m/BDL.	40

RP-40C

Kg/m	0.980
m/PC	4
m/BDL.	40

ROLLER TRACKS (ODM)

R-40BH2B

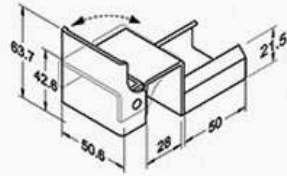
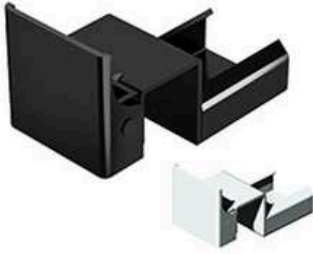

Kg/PC	0.167
PC/CTN	50

R-40BH4A

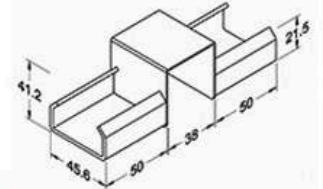
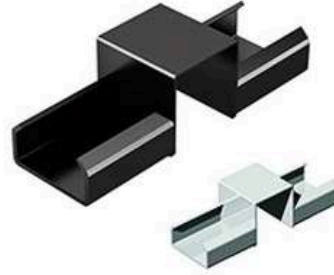

Kg/PC	0.213
PC/CTN	30

R-40BH4B

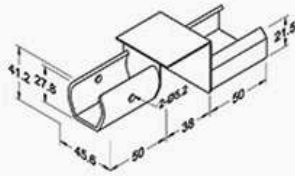
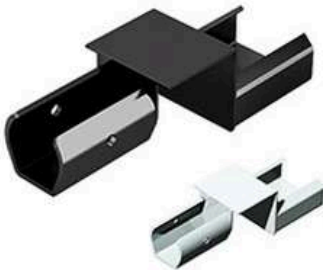

Kg/PC	0.190
PC/CTN	40

R-40H2A

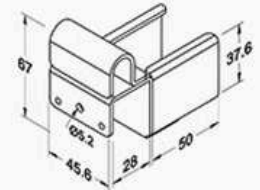

Kg/PC	0.234
PC/CTN	45

R-40H4A

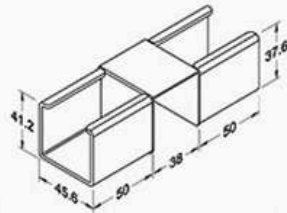
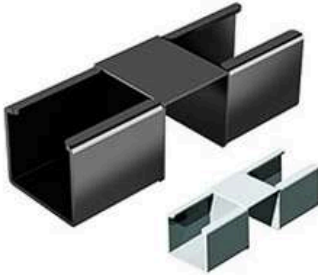

Kg/PC	0.290
PC/CTN	25

R-4040H1

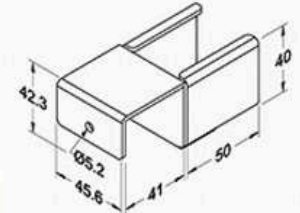

Kg/PC	0.220
PC/CTN	45

R-4040H3

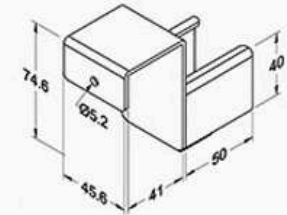

Kg/PC	0.250
PC/CTN	35

R-44H1

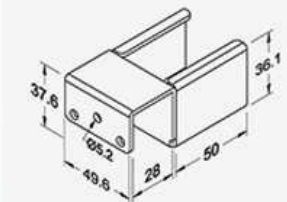

Kg/PC	0.186
PC/CTN	40

R-44H3

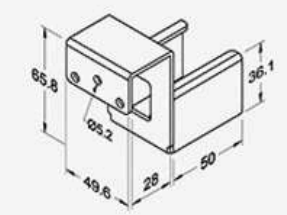

Kg/PC	0.220
PC/CTN	35

R-85H2A

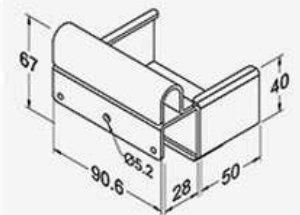

Kg/PC	0.405
PC/CTN	30

ROLLER TRACKS (R-60H)

SURFACE : ◉wz

R-60BH1

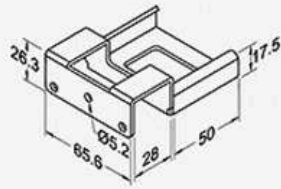

Kg/PC	0.220
PC/CTN	50

R-60BH2

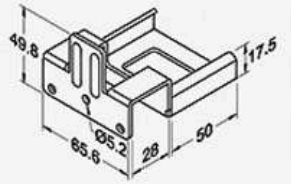
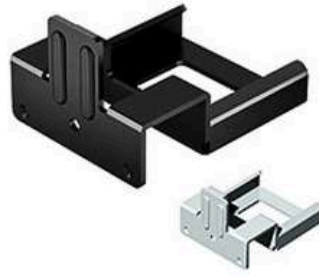

Kg/PC	0.300
PC/CTN	35

R-60BH3

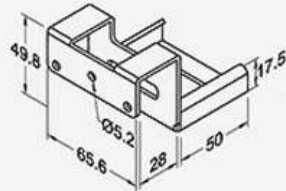

Kg/PC	0.240
PC/CTN	45

R-60BH4

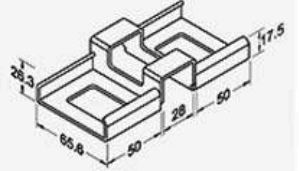
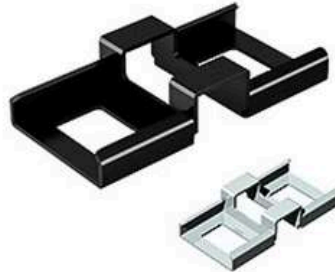

Kg/PC	0.263
PC/CTN	50

R-60BH5

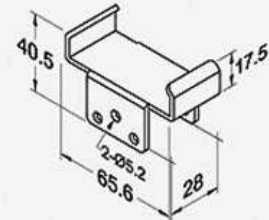

Kg/PC	0.140
PC/CTN	70

R-60BH6

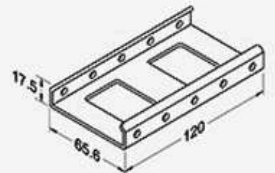

Kg/PC	0.215
PC/CTN	80

R-60BH6A

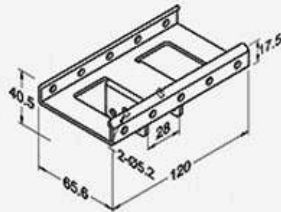

Kg/PC	0.267
PC/CTN	35

R-60BH31

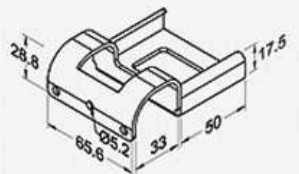

Kg/PC	0.267
PC/CTN	35

R-60BH33

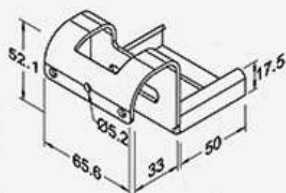

Kg/PC	0.267
PC/CTN	35

ROLLER TRACKS (R-80H)

R-80BH1

Kg/PC	0.220
PC/CTN	50

R-80BH2

Kg/PC	0.300
PC/CTN	35

R-80BH3

Kg/PC	0.240
PC/CTN	45

R-80BH4

Kg/PC	0.263
PC/CTN	50

R-80BH5

Kg/PC	0.140
PC/CTN	70

R-80BH6

Kg/PC	0.215
PC/CTN	80

R-80BH6A

Kg/PC	0.267
PC/CTN	35

R-80BH31

Kg/PC	0.267
PC/CTN	35

R-80BH33

Kg/PC	0.267
PC/CTN	35

R
Series

ROLLER TRACKS (R-85H)

SURFACE : ◉ WZ

R-85BH1

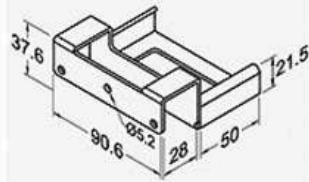

Kg/PC	0.220
PC/CTN	50

R-85BH2

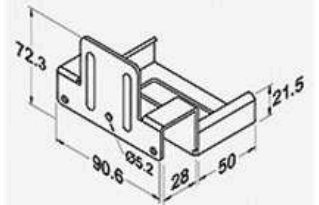
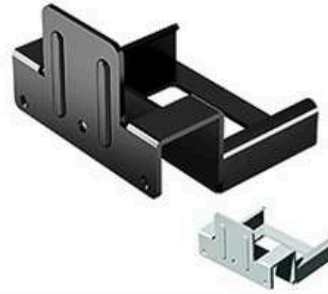

Kg/PC	0.300
PC/CTN	35

R-85BH3

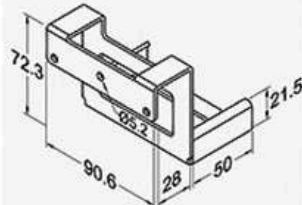

Kg/PC	0.240
PC/CTN	45

R-85BH4

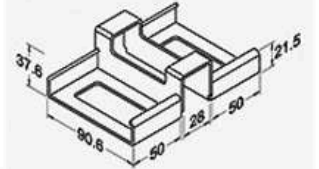
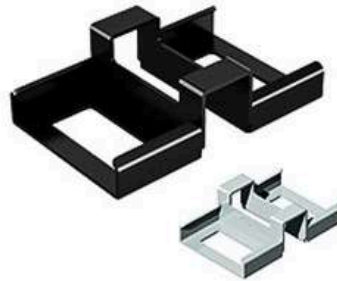

Kg/PC	0.263
PC/CTN	50

R-85BH5

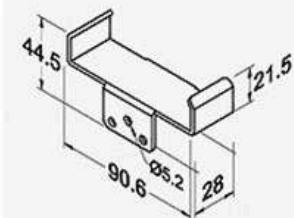

Kg/PC	0.140
PC/CTN	70

R-85BH6

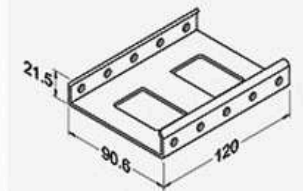

Kg/PC	0.215
PC/CTN	80

R-85BH6A

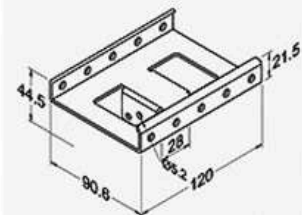

Kg/PC	0.267
PC/CTN	35

R-85BH31

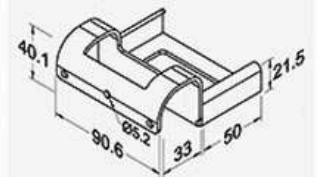

Kg/PC	0.267
PC/CTN	35

R-85BH33

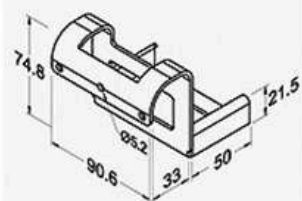

Kg/PC	0.267
PC/CTN	35

R-85H1

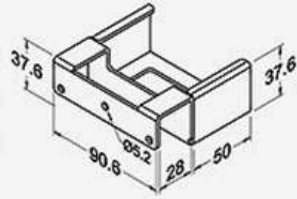

Kg/PC	0.220
PC/CTN	50

R-85H2

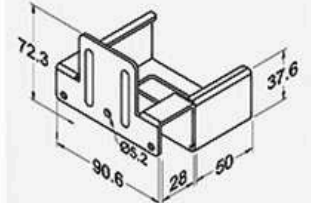

Kg/PC	0.300
PC/CTN	35

R-85H3

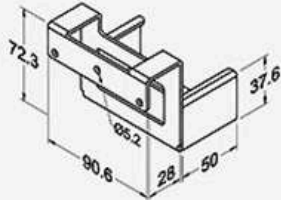

Kg/PC	0.240
PC/CTN	20

R-85H31

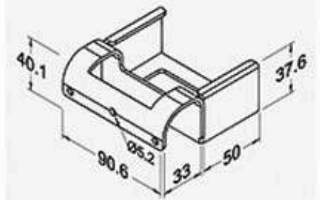

Kg/PC	0.300
PC/CTN	35

R-85H33

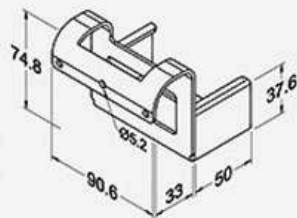

Kg/PC	0.240
PC/CTN	45

P Series
PLASTICS



PLASTICS

P-1

Kg/PC	0.003
PC/CTN	400

P-1A

Kg/PC	0.003
PC/CTN	400

P-2

Kg/PC	0.009
PC/CTN	200

P-2A

Kg/PC	0.017
PC/CTN	100

P-3

Kg/PC	0.005
PC/CTN	300

P-4

Kg/PC	0.005
PC/CTN	300

P-5

Kg/PC	0.003
PC/CTN	500

P-6

Kg/PC	0.006
PC/CTN	150

P-7

Kg/PC	0.010
PC/CTN	200

P-7A

Kg/PC	0.012
PC/CTN	200

Unit : mm

P-8

Kg/PC	0.005
PC/CTN	300

P-9

Kg/PC	0.014
PC/CTN	100

P-10

Kg/PC	0.014
PC/CTN	100

P-11

Kg/PC	0.018
PC/CTN	100

P-13

Kg/PC	0.014
PC/CTN	100

P-14

Kg/PC	0.042
PC/CTN	100

P-L1

Kg/PC	0.040
PC/CTN	60

P-L1A

Kg/PC	0.053
PC/CTN	50

P-L2

Kg/PC	0.014
PC/CTN	120

P-L2A

Kg/PC	0.022
PC/CTN	60

P Series

PLASTICS

P-L2B

Kg/PC	0.013
PC/CTN	100

P-L2C

Kg/PC	0.020
PC/CTN	60

P-L2D

Kg/PC	0.026
PC/CTN	50

P-L3

Kg/PC	0.006
PC/CTN	1000

P-L3A

Kg/PC	0.009
PC/CTN	700

P-L3B

Kg/PC	0.088
PC/CTN	100

P-L3C

Kg/PC	0.045
PC/CTN	150

P-L3D

Kg/PC	0.029
PC/CTN	500

P-L4

Kg/PC	0.045
PC/CTN	150



F Series

METAL ACCESSORIES

METAL ACCESSORIES

SURFACE : ◉ WZ

F-1

Kg/PC	0.158
PC/CTN	50

F-2

Kg/PC	0.200
PC/CTN	20

F-2A

Kg/PC	0.250
PC/CTN	10

F-3

Kg/PC	0.006
PC/CTN	800

F-3A

Kg/PC	0.001
PC/CTN	10000

F-3B

Kg/PC	0.020
PC/CTN	300

F-3C

Kg/PC	0.020
PC/CTN	300

F-4

Kg/PC	0.020
PC/CTN	300

F-4A (Use with F-10/F-10A/F-21)

Kg/PC	0.070
PC/CTN	150

F-5

Kg/PC	0.026
PC/CTN	200

Unit : mm

F-6

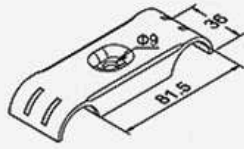

Kg/PC	0.104
PC/CTN	130

F-7

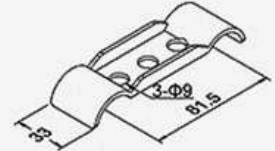

Kg/PC	0.079
PC/CTN	240

F-8

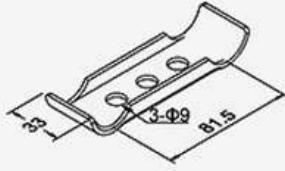

Kg/PC	0.082
PC/CTN	240

F-9

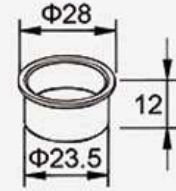

Kg/PC	0.013
PC/CTN	800

F-9A

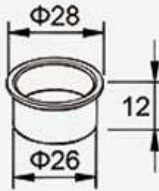

Kg/PC	0.013
PC/CTN	800

F-10 (Use with F-4A/F-10A/F-21)

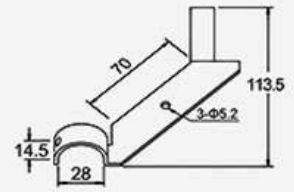

Kg/PC	0.072
PC/CTN	90

F-10A (Use with F-4A/F-10/F-21)

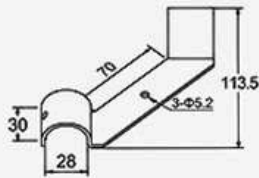

Kg/PC	0.106
PC/CTN	75

F-10B (Use with F-4A/F-10/F-21)

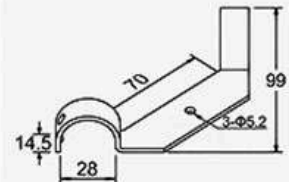

Kg/PC	0.065
PC/CTN	75

F-11

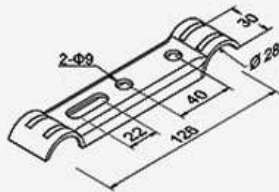

Kg/PC	0.108
PC/CTN	120

F-11A

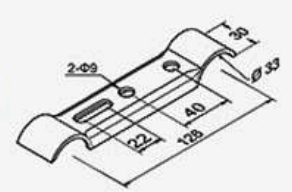

Kg/PC	0.109
PC/CTN	120

METAL ACCESSORIES

SURFACE : ●BK ○WZ

F-12A/F-12B/F-12C

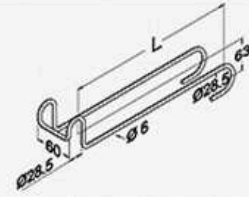

Part No.	F-12A	F-12B	F-12C
L	235	335	435
Kg/PC	0.183	0.225	0.255
PC/CTN	40	30	25

F-13A/F-13B/F-13C/F-13D

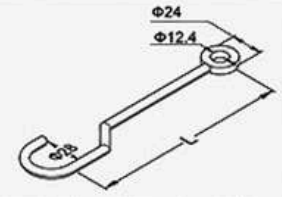

Part No.	F-13A	F-13B	F-13C	F-13D
L	60	100	150	200
Kg/PC	0.039	0.046	0.059	0.070
PC/CTN	350	230	180	150

F-14

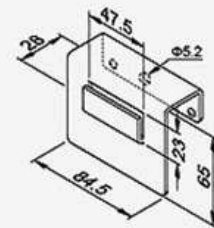

Kg/PC	0.188
PC/CTN	60

F-15

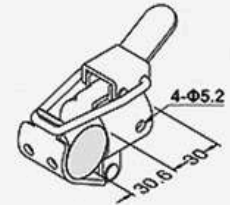

Kg/PC	0.145
PC/CTN	75

F-16

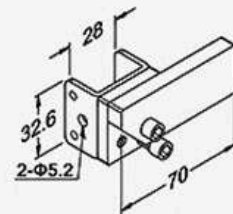

Kg/PC	0.230
PC/CTN	130

F-17

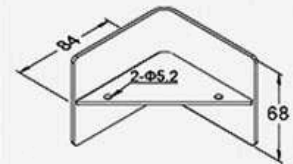

Kg/PC	0.275
PC/CTN	25

F-18

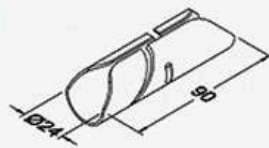

Kg/PC	0.060
PC/CTN	120

F-18A

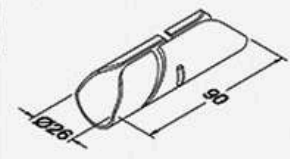

Kg/PC	0.060
PC/CTN	120

F-19



Kg/PC	0.015
PC/CTN	200

F-20

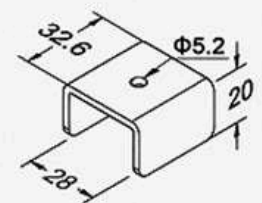

Kg/PC	0.037
PC/CTN	500

Unit : mm

F-21 (Use with F-4A/F-10/F-10A)

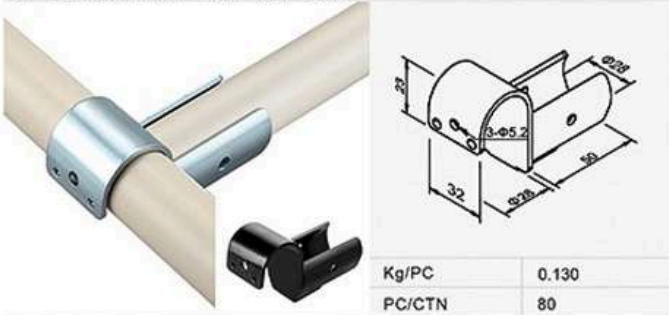

Kg/PC	0.130
PC/CTN	80

F-22

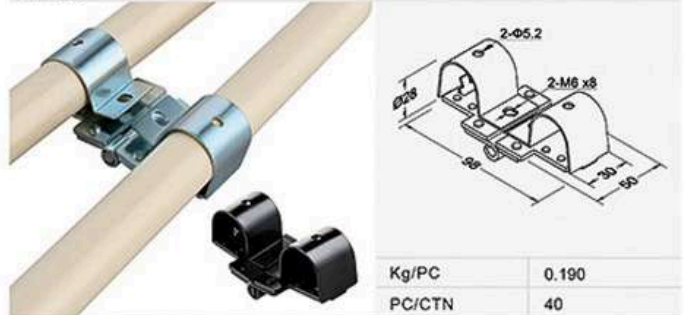

Kg/PC	0.190
PC/CTN	40

F-25A

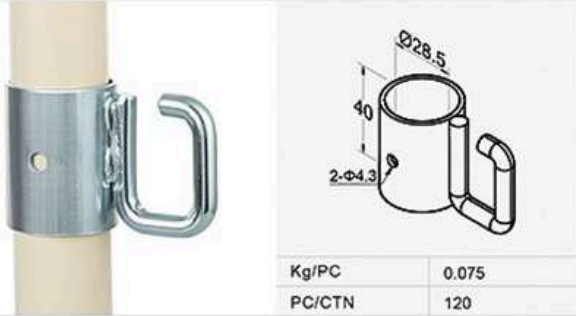

Kg/PC	0.075
PC/CTN	120

F-25B

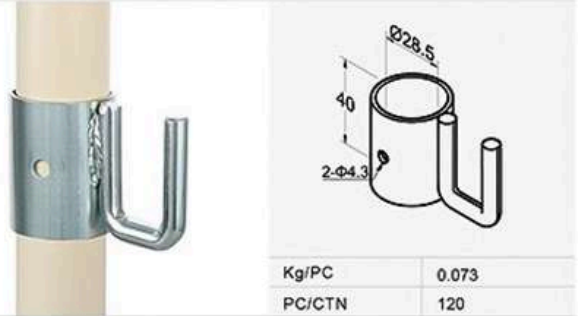

Kg/PC	0.073
PC/CTN	120

F-25C

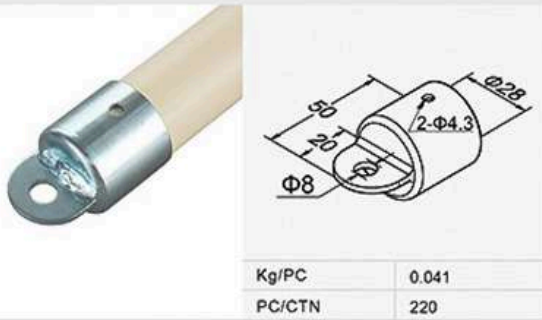

Kg/PC	0.041
PC/CTN	220

F-26



Kg/PC	0.009
PC/CTN	400

F-27



Kg/PC	0.041
PC/CTN	220

L Series

L Series

LEVELING FEET



METAL ACCESSORIES

SURFACE : ◉ WZ

L-1

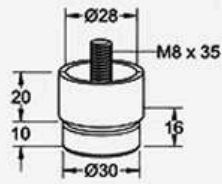

Kg/PC	0.043
PC/CTN	180

L-2

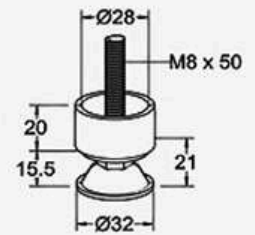

Kg/PC	0.052
PC/CTN	140

L-2A

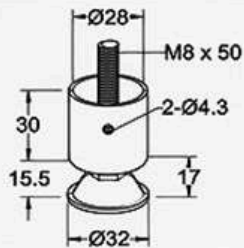

Kg/PC	0.068
PC/CTN	130

L-3

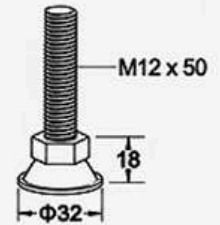

Kg/PC	0.071
PC/CTN	200

L-3A

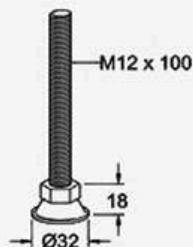

Kg/PC	0.104
PC/CTN	130

L-3B

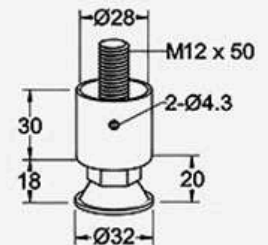

Kg/PC	0.100
PC/CTN	120

L-3C

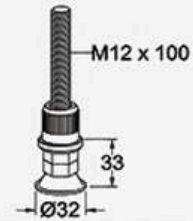

Part No.	L-3CCP10	L-3CCP12
Kg/PC	0.191	0.191
PC/CTN	100	100

L-3D

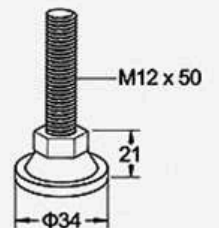

Kg/PC	0.074
PC/CTN	200

L-4

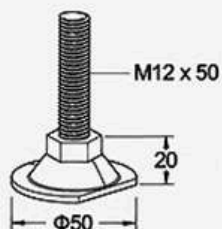

Kg/PC	0.094
PC/CTN	120

L-4A

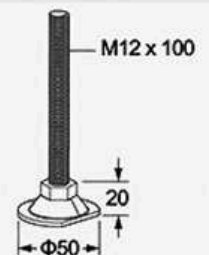

Kg/PC	0.129
PC/CTN	80

L-4B

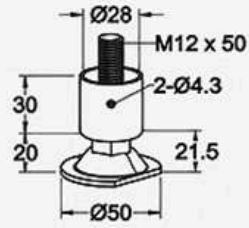

Kg/PC	0.125
PC/CTN	85

L-4C

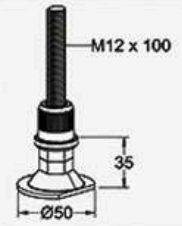

Part No.	L-4CCP10	L-4CCP12
Kg/PC	0.215	0.215
PC/CTN	70	70

L-4D



Kg/PC	0.094
PC/CTN	120

L-4E



Kg/PC	0.105
PC/CTN	100

L-4F

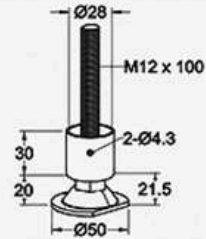

Kg/PC	0.180
PC/CTN	100

L-5

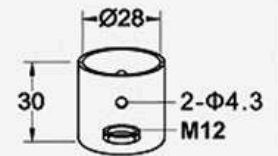

Kg/PC	0.033
PC/CTN	200

L-6

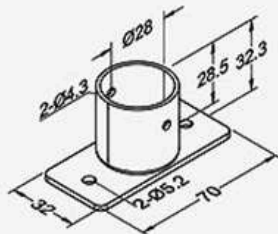

Kg/PC	0.073
PC/CTN	120

L-6A

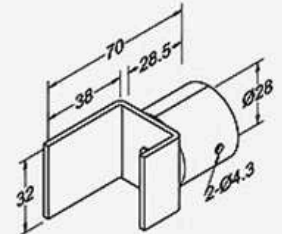

Kg/PC	0.083
PC/CTN	140

L-6B

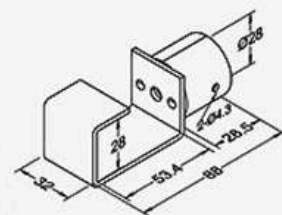

Kg/PC	0.112
PC/CTN	100

L-6C

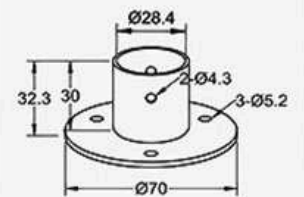

Kg/PC	0.103
PC/CTN	80

Series

METAL ACCESSORIES

L-7

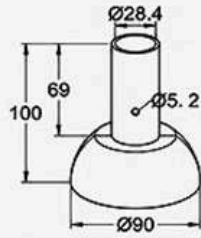

Kg/PC	0.395
PC/CTN	15

L-8

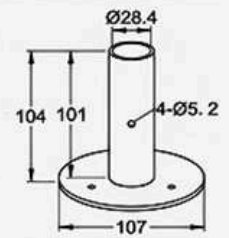

Kg/PC	0.460
PC/CTN	15

L-9

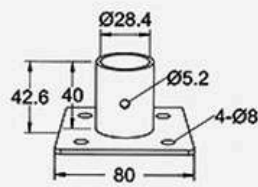

Kg/PC	0.230
PC/CTN	30

N Series
FASTENERS



FASTENERS

Picture	Part No.	Desc.	Surface	Kg/PC	PC/CTN	Apply
	N-1M6BZ	Nut	BZ	0.002	5400	Bolt
	N-1M6BL		BL			
	N-1M6WZ		WZ			
	N-1ENBZ	Nut	BZ	0.002	5400	Inch Bolt
	N-1ENWZ		WZ			
N-2						
	N-2BZ	Bolt	BZ	0.007	2700	Nut
	N-2BL		BL			
	N-2WZ		WZ			
	N-2ENBZ	Bolt	BZ	0.007	2700	Inch Nut
	N-2ENWZ		WZ			
N-2						
	N-2M612BZ	Bolt	BZ	0.005	4000	Nut
	N-2M612WZ		WZ			
N-3						
	N-3M840WZ	Bolt	WZ	0.017	1200	M8 Nut
N-6						
	N-6M8WZ	Nylon Nut	WZ	0.002	4000	M8 Bolt
Picture	Part No.	Classification	Application	Kg/PC	PC/CTN	Apply
	N-8ACP10M10WZ	Coated Pipe	Φ28 x T1.0	0.075	350	Φ24.0
	N-8ASUS09M10WZ	SUS Pipe	Φ28 x T0.9	0.084	320	Φ26.0
	N-8ASUS11M10WZ		Φ28 x T1.1	0.090		Φ25.6
N-8A (M12)						
	N-8ACP07M12WZ	Coated Pipe	Φ28 x T0.7	0.075	350	Φ24.6
	N-8ACP10M12WZ		Φ28 x T1.0			Φ24.0
	N-8ACP14M12WZ		Φ28 x T1.4			Φ23.2
	N-8ACP20M12WZ		Φ28 x T2.0			Φ22.0
	N-8ASUS07M12WZ	SUS Pipe	Φ28 x T0.7	0.084	320	Φ26.4
	N-8ASUS09M12WZ		Φ28 x T0.9	0.090		Φ26.0
	N-8ASUS11M12WZ		Φ28 x T1.1	Φ25.6		
N-9						
	N-9	Srew Set	NA	0.030	0000	Srew Set













C Series

CASTERS

CASTERS

Picture	Part No.	 (mm)	Wheel Material	 (mm)	 (Kg)	 (mm)	 (mm)
C-4A							
	C-4ATPR75GM12	75	TPR	32	100	104	M12 X 60
	C-4ATPR100GM12	100	TPR	32	130	130	M12 X 60
C-4							
	C-4TPR75GM12	75	TPR	32	100	104	M12 X 60
	C-4TPR100GM12	100	TPR	32	130	130	M12 X 60
C-4A ESD							
	C-4ATPRESD75GM12	75	TPR ESD	32	100	104	M12 X 60
	C-4ATPRESD100GM12	100	TPR ESD	32	130	130	M12 X 60
C-4 ESD							
	C-4TPRESD75GM12	75	TPR ESD	32	100	104	M12 X 60
	C-4TPRESD100GM12	100	TPR ESD	32	130	130	M12 X 60

Picture	Part No.	 (mm)	Wheel Material	 (mm)	 (Kg)	 (mm)	 (mm)	 (mm)
C-5								
	C-5TPR100G	100	TPR	32	130	128	95 X 67	73 X 45
C-7								
	C-7TPR100G	100	TPR	32	130	128	95 X 67	73 X 45
C-8								
	C-8TPR150G	150	TPR	50	410	190	114 X 100	84 X 71
C-10A								
	C-10ATPR150G	150	TPR	50	410	190	114 X 100	84 X 71

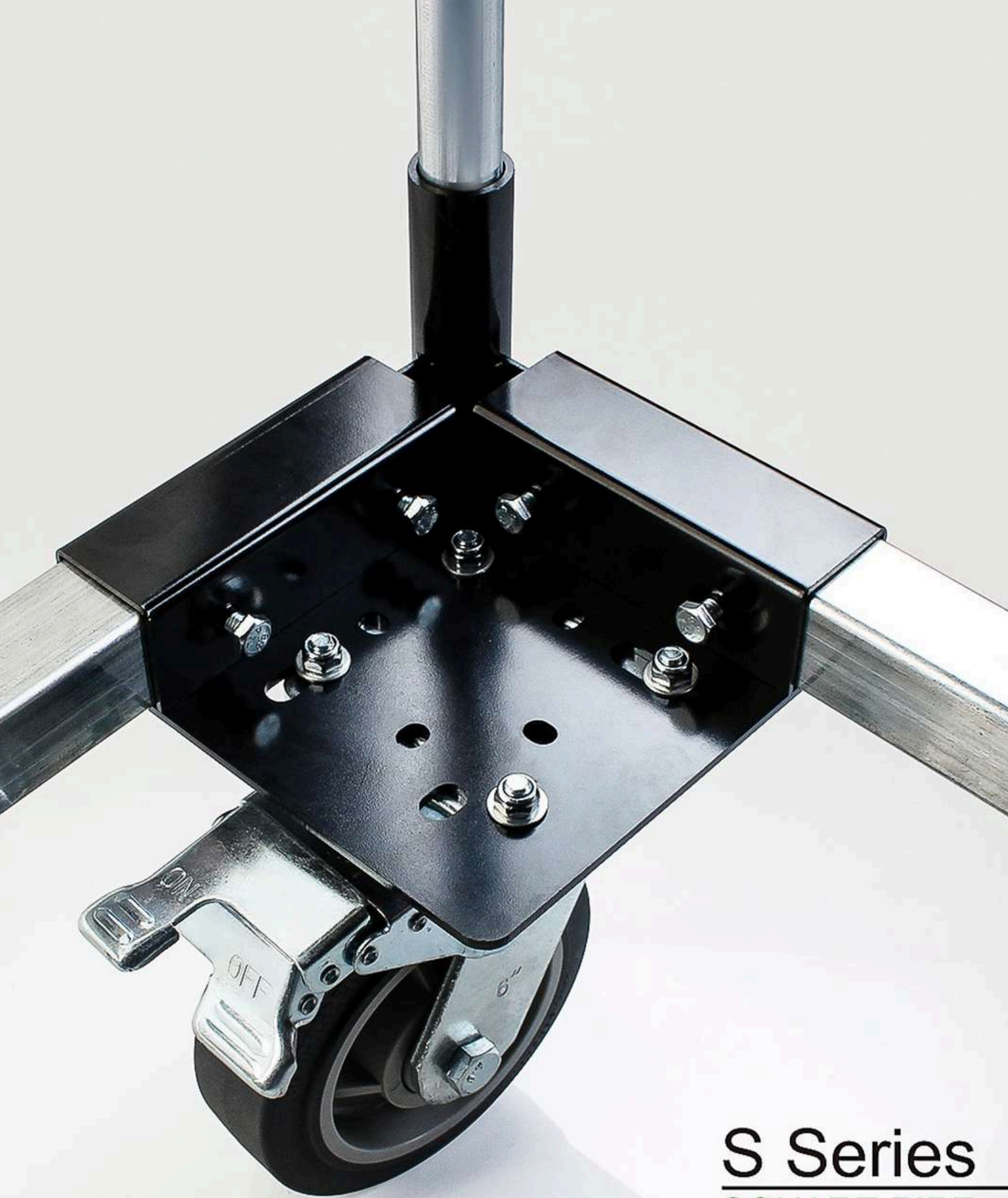

S Series

SQUARE PIPE

Square Pipe

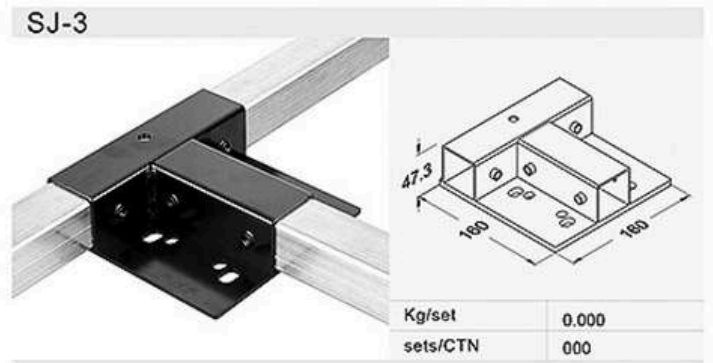
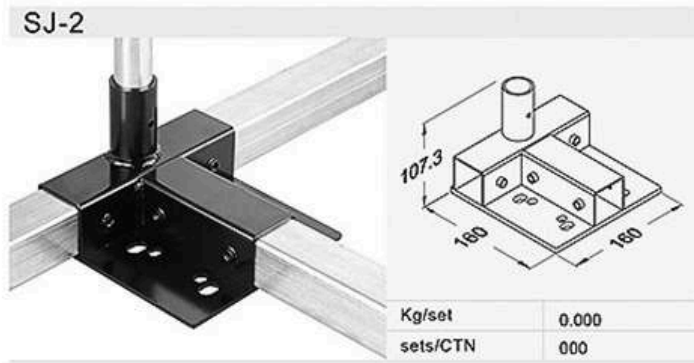
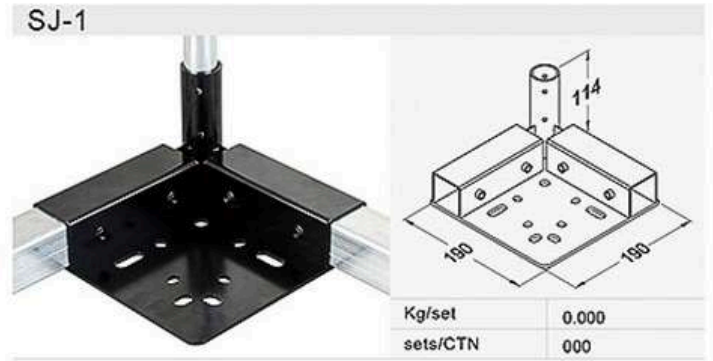
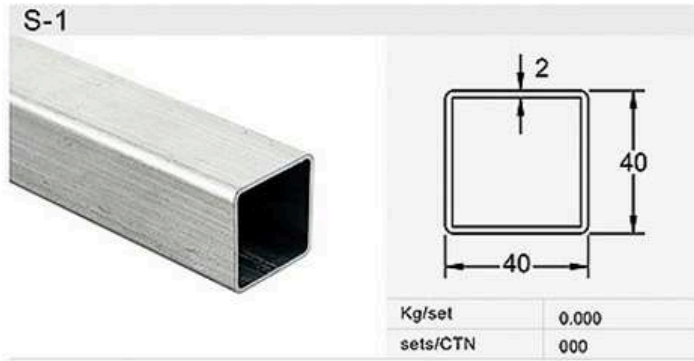



LEAN MANUFACTURING



DTECH SOLUTIONS

Rodovia Adhemar de Barros, SP 340
KM 161,1 - N° 2800 Jardim Maria Bonati Bordignon
Mogi Mirim - SP, CEP: 13803-070

 **+55 19 3862-9677**

 **+55 19 99755-9892**

 **contato@dtechsolutions.com.br**



@dtechsolutionsbr